

Uni-Directional (Metal Seated)

Manual Handwheel

Style KGV2

Carbon Steel Technical Data 150 PSI 2” – 24”3

304 Stainless Steel Technical Data 150 PSI 2” – 24”3

316 Stainless Steel Technical Data 150 PSI 2” – 24”3

Bi-Directional (Resilient Seated)

Manual Handwheel

Style KGV2

Carbon Steel Technical Data 150 PSI 2” – 24”4

304 Stainless Steel Technical Data 150 PSI 2” – 24”4

316 Stainless Steel Technical Data 150 PSI 2” – 24”4

Fabricated

Bevel Gear Operator

Bi-Directional Metal Seat 150 PSI 30” – 60”5

Bi-Directional Resilient Seat 150 PSI 30” – 60”6

Features

Knife Gate Valve

Exploded View7

Packing Options7

Style KGV

Carbon Steel (ASTM A 216, Grade WCB)

150 PSI

Stainless Steel (ASTM A 351, Grade CF8)

150 PSI

Stainless Steel (ASTM A 351, Grade CF8M)

150 PSI

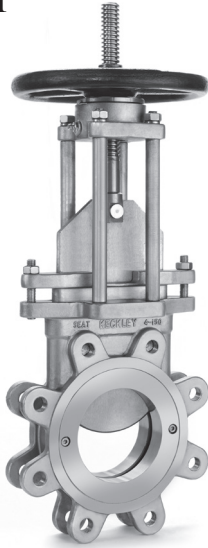

Cylinder Actuation
2" - 24"



Bevel Gear Actuation
2" - 24"

Knife Gate Valve

APPLICATIONS

Pulp and paper, chemical, petrochemical, power, mining, waste water, food processing, and beverage where shut-off of liquids is required.

CONSTRUCTION

The Keckley Style KGV Knife Gate Valves are constructed from rugged castings that are machined to exacting specifications.

FEATURES

- Meets TAPPI TIS 405-8 and MSS SP-81 Standards on wafer-type knife gate valves for face to face dimensions.
- Flanges match ASME B16.5 Class 150. Holes tapped.
- 150 PSIG (10.3 Bar) max. working pressure. 150°F (65°C) max. working temperature. Applications outside of their conditions require special design considerations.
- Gate edge is beveled for easier packing seal and longer packing life.
- Meets MSS SP-81 shut-off requirements of 40cc per inch per minute at 40 PSI (water test).
- Non-clogging large port.
- Port diameter exceeds requirements of MSS SP-81.
- Replaceable resilient seats extend the service life of the valve. Resilient seats can be easily replaced after removing the valve from the line.

AVAILABLE OPTIONS

Actuation

- Manual Handwheel
- Double Acting Hydraulic Cylinder Operator
- Bevel Gear Operators
- Double Acting Spring-Return Pneumatic Cylinder Operator

Automation

- Mechanical Limit Switches for Position Indication
- Proximity Limit Switches for Position Indication

ORDERING

Reference product number table for proper ordering code.

Style KGV

**Knife Gate Valve, 150 PSI, Large Port, Metal Seat
Uni-Directional with Manual Hand Wheel**

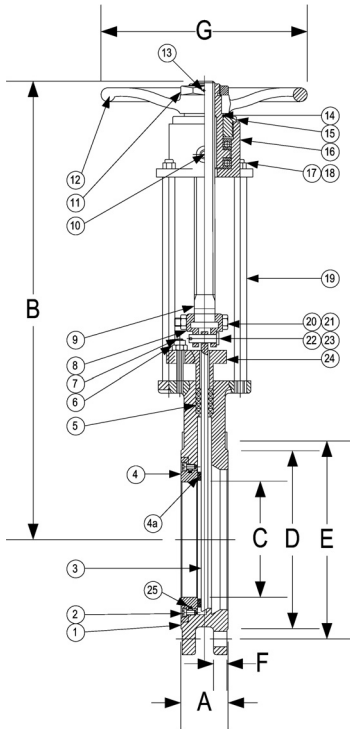

Product Numbers								
Size	Class	Valve Type	-	Body Material	-	Valve Seat Surface	Directional Flow	Actuation
	2	KGV	-	CS	-	M	U	M

CS	Carbon Steel
34	304 Stainless Steel
36	316 Stainless Steel

M	Metal (Same as Valve Seat)
---	----------------------------

PARTS LIST				
ITEM	DESCRIPTION	MATERIAL		
1	Body	WCB (CS)	CF8 (304ss)	CF8M (316ss)
2	Inner Hex Head Screws (2)	A 193, B7	A 193, B8	A 193, B8
3	Gate	A 276, 304	A 276, 304	A 276, 316
4	Valve Seat	A 216, WCB	A 351, CF8	A 351, CF8M
4a	Valve Seat Surface*	A216, WCB	A 351, CF8	A 351, CF8M
5	Packing	PTFE	PTFE	PTFE
6,18,21	Nut	A 194, 2H	A 194, 8	A 194, 8
7	Stud	A 193, B7	A 193, B8	A 193, B8
8	Clamp Plate	A 216, WCB	A 351, CF8	A 351, CF8
9	Stem	A276, 410	A 276, 304	A 276, 304
10	Grease Fitting	A 276, 304	A 276, 304	A 276, 304
11	Handwheel Nut	AISI 1025	AISI 1025	AISI 1025
12	Handwheel	A 536	A 536	A 536
13	Screw	A 193, B7	A 193, B8	A 193, B8
14	Stem Nut	B 148	B 148	B 148
15	Gland	A 216, WCB	A 351, CF8	A 351, CF8
16	Top of Yoke	A 216, WCB	A 351, CF8	A 351, CF8
17	Spring Washer	AISI 1065	A 276, 304	A 276, 304
19	Post (Chrome Plated)	AISI 1035	AISI 1035	AISI 1035
20	Bolt	A 193, B7	A 193, B8	A 193, B8
22	Straight Pin	AISI 1035	A 276, 304	A 276, 304
23	Cotter Pin	A 276, 304	A 276, 304	A 276, 304
24	Packing Gland	A 216, WCB	A 351, CF8	A 351, CF8
25	O-Ring**	(See Below)		

*Consult factory for Valve Seat Surface Options: Buna-N, Viton, EPDM, and PTFE.
**O-Ring Options: Buna-N, Viton, EPDM, and PTFE.
Consult factory for actuation options: Bevel Gear, Air Cylinder, Hydraulic Cylinder, or Motor Operated.

SIZE		DIMENSIONS												WEIGHTS			
		A		B		C		D		E		F				G	
in	mm	in	mm	in	mm	in	mm	in	mm	in	mm	in	mm	in	mm	lbs	kgs
2	50	1.88	48	10.83	275	1.81	46	3.62	92	4.75	120.7	0.50	12.7	8.00	203	20	9
2-1/2	65	2.00	51	11.81	300	2.36	60	4.13	105	5.50	139.5	0.50	12.7	8.00	203	23	10.5
3	80	2.00	51	12.52	318	2.76	70	5.00	127	6.00	152.5	0.50	12.7	8.00	203	27	12
4	100	2.00	51	14.80	376	3.78	96	6.20	157.5	7.50	190.5	0.50	12.7	8.00	203	35	16
6	150	2.25	57	19.29	490	5.71	145	8.50	216	9.50	241.5	0.63	16	10.00	255	57	26
8	200	2.75	70	22.83	580	7.64	194	10.63	270	11.75	298.5	0.63	16	12.00	305	86	39
10	250	2.75	70	28.15	715	9.65	245	12.76	324	14.25	362	0.75	19.1	14.00	356	141	64
12	300	3.00	76	33.27	845	11.81	300	15.00	381	17.00	432	0.75	19.1	14.00	356	187	85
14	350	3.00	76	37.36	949	12.99	330	16.26	413	18.75	476	0.81	20.6	16.00	406	265	120
16*	400	3.50	89	56.20	1427.5	14.96	380	18.50	470	21.25	540	0.88	22.4	12.00	310	381	173
18*	450	3.50	89	62.40	1585	16.54	420	21.00	533.5	22.75	578	0.94	23.9	12.00	310	474	215
20*	500	4.50	114	68.28	1734	18.50	470	23.00	584.5	25.00	635	1.00	25.4	18.00	460	637	289
24*	600	4.50	114	79.92	2030	22.44	570	27.26	692.5	29.50	749.5	1.00	25.4	18.00	460	884	401

*16" - 24" standard with Bevel Gear. (Not Shown)
Larger sizes available upon request. Consult factory.
†This table reflects only the nearest metric equivalents.

Reference Standards
MSS SP-81
TIS 405-8

Size	Standard Cv*	V-Port Cv*	Leakage† (cc/min)		Size	Standard Cv*	V-Port Cv*	Leakage† (cc/min)	
			TAPPI Allow.	Keckley Actual				TAPPI Allow.	Keckley Actual
2	340	85	80	0-20	12	15,300	2,850	480	0-100
3	850	195	120	0-20	14	19,000	3,750	560	0-100
4	1,500	340	160	0-40	16	25,500	4,900	640	0-100
6	3,500	800	240	0-60	18	36,000	6,500	720	0-100
8	6,600	1,400	320	0-80	20	45,000	8,000	800	0-100
10	9,800	1,900	400	0-100	24	60,000	12,000	960	0-100

*Tested in accordance with ASME/ISA-575-02.
†Test pressure 40 psi water (TAPPI and MSS SP-81).

Style KGV

**Knife Gate Valve, 150 PSI, Large Port, Resilient Seat
Bi-Directional with Manual Hand Wheel**

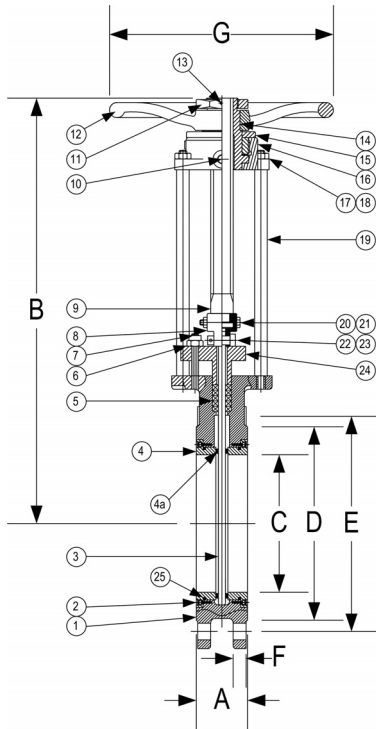

PARTS LIST				
ITEM	DESCRIPTION	MATERIAL		
1	Body	WCB (CS)	CF8 (304ss)	CF8M (316ss)
2	Inner Hex Head Screws (4)	A 193, B7	A 193, B8	A 193, B8
3	Gate	A 276, 304	A 276, 304	A 276, 316
4	Valve Seats (2)	A 216, WCB	A 351, CF8	A 351, CF8M
4a	Valve Seat Surface* (2)	(See Below)		
5	Packing	PTFE	PTFE	PTFE
6,18,21	Nut	A 194, 2H	A 194, 8	A 194, 8
7	Stud	A 193, B7	A 193, B8	A 193, B8
8	Clamp Plate	A 216, WCB	A 351, CF8	A 351, CF8
9	Stem	A276, 410	A 276, 304	A 276, 304
10	Grease Fitting	A 276, 304	A 276, 304	A 276, 304
11	Handwheel Nut	AISI 1025	AISI 1025	AISI 1025
12	Handwheel	A 536	A 536	A 536
13	Screw	A 193, B7	A 193, B8	A 193, B8
14	Stem Nut	B 148	B 148	B 148
15	Gland	A 216, WCB	A 351, CF8	A 351, CF8
16	Top of Yoke	A 216, WCB	A 351, CF8	A 351, CF8
17	Spring Washer	AISI 1065	A 276, 304	A 276, 304
19	Post (Chrome Plated)	AISI 1035	AISI 1035	AISI 1035
20	Bolt	A 193, B7	A 193, B8	A 193, B8
22	Straight Pin	AISI 1035	A 276, 304	A 276, 304
23	Cotter Pin	A 276, 304	A 276, 304	A 276, 304
24	Packing Gland	A 216, WCB	A 351, CF8	A 351, CF8
25	O-Rings (2)	(Same as 4a)		

*Valve Seat Surface Options: Buna-N, Viton, EPDM, and PTFE.
Consult factory for actuation options: Bevel Gear, Air Cylinder, Hydraulic Cylinder, or Motor Operated.

Product Numbers						
Size	Class	Valve Type	Body Material	Valve Seat Surface	Directional Flow	Actuation
	2	KGV	- 36	- B	B	M

CS	Carbon Steel	B	Buna-N
34	304 Stainless Steel	V	Viton
36	316 Stainless Steel	E	EPDM
		P	PTFE

SIZE		DIMENSIONS														WEIGHTS	
		A		B		C		D		E		F		G			
in	mm	in	mm	in	mm	in	mm	in	mm	in	mm	in	mm	in	mm	lbs	kgs
2	50	1.88	48	10.83	275	1.81	46	3.62	92	4.75	120.7	0.50	12.7	8.00	203	20	9
2-1/2	65	2.00	51	11.81	300	2.36	60	4.13	105	5.50	139.5	0.50	12.7	8.00	203	23	10.5
3	80	2.00	51	12.52	318	2.76	70	5.00	127	6.00	152.5	0.50	12.7	8.00	203	27	12
4	100	2.00	51	14.80	376	3.78	96	6.20	157.5	7.50	190.5	0.50	12.7	8.00	203	35	16
6	150	2.25	57	19.29	490	5.71	145	8.50	216	9.50	241.5	0.63	16	10.00	255	57	26
8	200	2.75	70	22.83	580	7.64	194	10.63	270	11.75	298.5	0.63	16	12.00	305	86	39
10	250	2.75	70	28.15	715	9.65	245	12.76	324	14.25	362	0.75	19.1	14.00	356	141	64
12	300	3.00	76	33.27	845	11.81	300	15.00	381	17.00	432	0.75	19.1	14.00	356	187	85
14	350	3.00	76	37.36	949	12.99	330	16.26	413	18.75	476	0.81	20.6	16.00	406	265	120
16*	400	3.50	89	56.20	1427.5	14.96	380	18.50	470	21.25	540	0.88	22.4	12.00	310	381	173
18*	450	3.50	89	62.40	1585	16.54	420	21.00	533.5	22.75	578	0.94	23.9	12.00	310	474	215
20*	500	4.50	114	68.28	1734	18.50	470	23.00	584.5	25.00	635	1.00	25.4	18.00	460	637	289
24*	600	4.50	114	79.92	2030	22.44	570	27.26	692.5	29.50	749.5	1.00	25.4	18.00	460	884	401

*16" - 24" standard with Bevel Gear. (Not Shown)
Larger sizes available upon request. Consult factory.
*This table reflects only the nearest metric equivalents.

Valve Seat Surface Options	Operating Temperature**		Reference Standards
	°F	°C	
Buna-N	-20 to 250	-29 to 121	MSS SP-81
Viton	-20 to 400	-29 to 204	TIS 405-8
EPDM	-40 to 300	-40 to 149	
PTFE	-40 to 300	-40 to 149	

**Subject to limitations of body material.

Size	Standard Cv*	Leakage† (cc/min) Main Seat 1 - 150 PSI	Size	Standard Cv*	Leakage† (cc/min) Keckley Actual
2	340	0	12	15,300	0-20
3	850	0	14	19,000	0-20
4	1,500	0	16	25,500	0-40
6	3,500	0	18	36,000	0-60
8	6,600	0	20	45,000	0-80
10	9,800	0	24	60,000	0-100

*Tested in accordance with ASME/ISA-575-02.
†Test pressure 40 psi water (TAPPI and MSS SP-81).

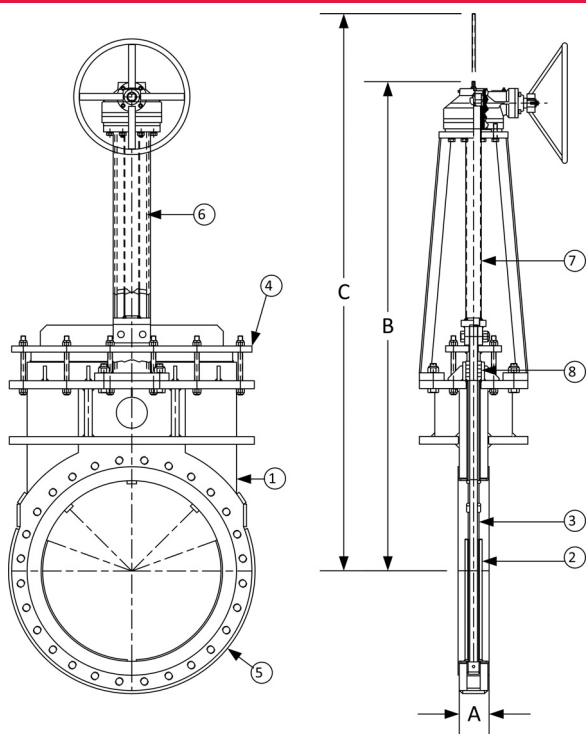

Style FKGV

Knife Gate Valve, Large Port, Metal Seat
Bi-Directional with Bevel Gear Operator
Fabricated Stainless Steel (304)

PARTS LIST		
ITEM	DESCRIPTION	MATERIAL
1	Body	Stainless Steel (304)
2	Seat	Stainless Steel (304)
3	Gate	Stainless Steel (304)
4	Packing Gland	Stainless Steel (304)
5	Flanges, Ext Trim	Stainless Steel (304)
6	Yoke Assembly	Stainless Steel (304)
7	Stem Assembly	Stainless Steel (304)
8	Packing	TFE/SYN

SIZE		DIMENSIONS						MAX PRESSURE		WEIGHTS	
		A		B		C					
in	mm	in	mm	in	mm	in	mm	PSI	KPa	lbs	kgs
30	750	4-5/8	117	74-3/4	1899	104	2642	125	862	TBD	TBD
36	900	5-3/4	146	89-1/8	2264	121	3073	125	862	TBD	TBD
42	1050	6-1/4	159	97-1/4	2470	136	3454	125	862	TBD	TBD
48	1200	7	178	110	2794	155	3937	125	862	TBD	TBD
54	1350	6-5/8	168	123	3124	173	4394	50	345	TBD	TBD
60	1500	7	178	135	3429	189	4801	50	345	TBD	TBD

†This table reflects only the nearest metric equivalents.

Product Numbers							
Size	Valve Type	-	Body Material	-	Seat Material	Directional Flow	Actuation
	FKGV	-	34	-	M	B	B

↑
 M | Metal (Same as Valve Seat)

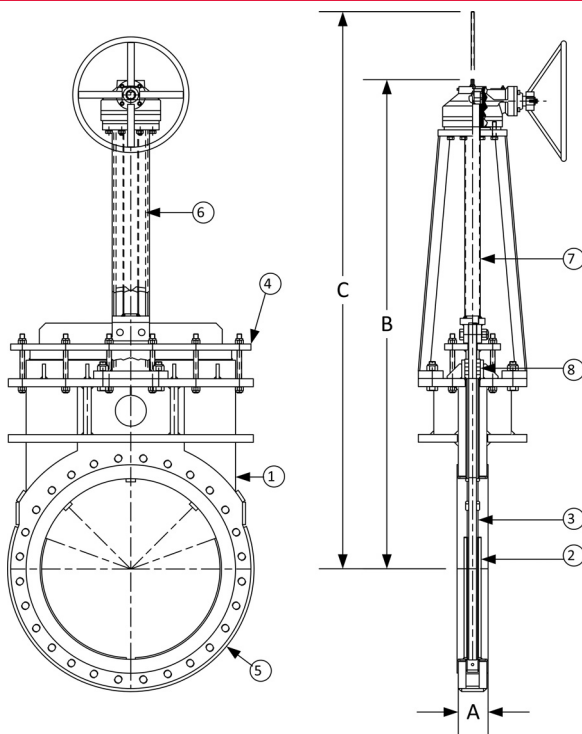

Style FKGV

Knife Gate Valve, Large Port, Resilient Seat
 Bi-Directional with Bevel Gear Operator
 Fabricated Stainless Steel (304)

PARTS LIST		
ITEM	DESCRIPTION	MATERIAL
1	Body	Stainless Steel (304)
2	Seat*	Viton
3	Gate	Stainless Steel (304)
4	Packing Gland	Stainless Steel (304)
5	Flanges, Ext Trim	Stainless Steel (304)
6	Yoke Assembly	Stainless Steel (304)
7	Stem Assembly	Stainless Steel (304)
8	Packing	TFE/SYN

*Other Seat Options available in Buna-N, EPDM, and PTFE.

SIZE		DIMENSIONS						MAX PRESSURE		WEIGHTS	
		A		B		C					
in	mm	in	mm	in	mm	in	mm	PSI	KPa	lbs	kgs
30	750	4-5/8	117	74-3/4	1899	104	2642	125	862	TBD	TBD
36	900	5-3/4	146	89-1/8	2264	121	3073	125	862	TBD	TBD
42	1050	6-1/4	159	97-1/4	2470	136	3454	125	862	TBD	TBD
48	1200	7	178	110	2794	155	3937	125	862	TBD	TBD
54	1350	6-5/8	168	123	3124	173	4394	50	345	TBD	TBD
60	1500	7	178	135	3429	189	4801	50	345	TBD	TBD

†This table reflects only the nearest metric equivalents.

Seat Material	Operating Temperature**	
	°F	°C
Buna-N	-20 to 250	-29 to 121
Viton	-20 to 400	-29 to 204
EPDM	-40 to 300	-40 to 149
PTFE	-40 to 300	-40 to 149

**Subject to limitations of body material.

Product Numbers							
Size	Valve Type	-	Body Material	-	Seat Material	Directional Flow	Actuation
	FKGV	-	34	-	V	B	B

V	Viton
B	Buna-N
E	EPDM
P	PTFE

FEATURES

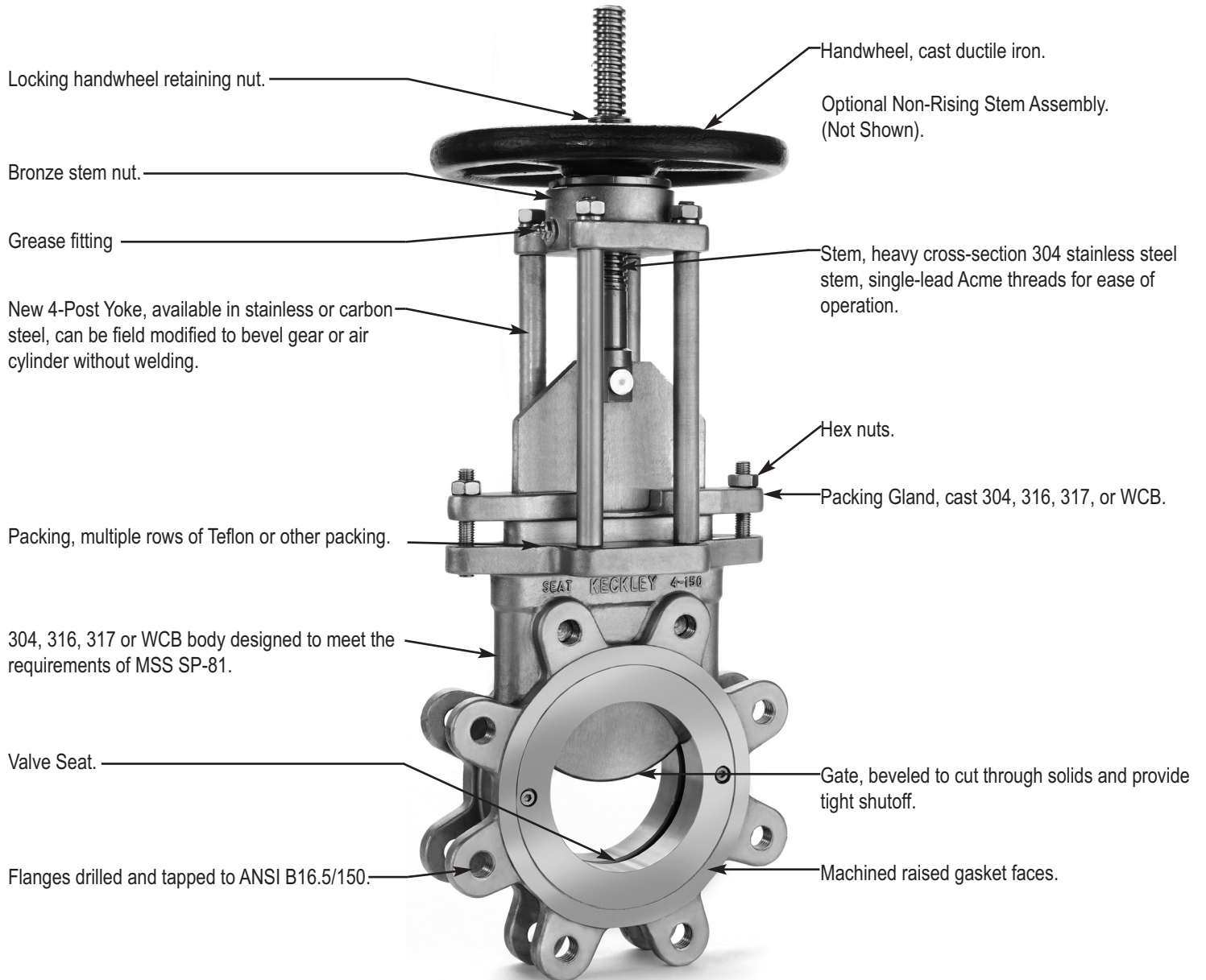

The Keckley Style KGV knife gate valves are available with numerous optional packing types and special packing arrangements to help ensure superior performance.

Standard Packing

Is an asbestos free Teflon impregnated synthetic suitable for services up to 500°F and a pH of 3-11, other packings include pure Teflon (0-13 pH) and food-grade Teflon and hi-temperature variations.

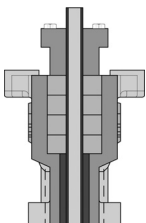

Gate Wiper

In viscous and scaling applications, a gate wiper can be added. Made from various materials, the wiper is fit to scrape the gate and deter solids from entering the packing area.

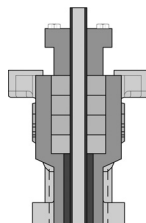

Enhanced Packing

Features Self-Mold SM636, a pliable packing material that forms itself to the interior of the packing box, filling any voids.

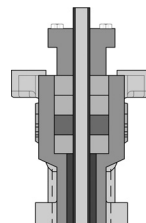

Cored Power Packing

Provides superior packing life with fewer adjustments, available in many different configurations.

